

## MB100 1 GHz Amplifier

STARLINE® Series



Motorola's 1 GHz STARLINE® Mini-Bridger® series amplifier, model MB100\*, leads the industry in features and performance and is designed to meet the needs of today's expanding broadband communication networks. This two-way capable dual output amplifier offers high gain, high output levels, ergonomics, superior distortion performance, multiple diplex filter options, 16 dB return loss, and Bode equalization. The MB100 also allows optional advanced features such as ingress control switching and status monitoring. A third output is user-configurable via splitter or directional coupler plug-in. Single output models are also available.

### ENHANCED GALLIUM ARSENIDE

The MB100 uses Enhanced Gallium Arsenide (E-GaAs) hybrids. This second generation technology provides superior distortion performance in CTB and CSO over the standard GaAs technology. Compared to silicon and competing GaAs technology, E-GaAs distortion performance remains linear at significantly higher output levels. This higher output level allows the customer to maximize system performance and reduce system costs. We encourage our customers to contact their Motorola Account Representative to determine the optimal levels for their systems.

### HIGH GAIN

The MB100 also offers high gain, which allows the operator to hold existing amplifier locations during system upgrades thereby reducing system costs such as maintenance, installation and powering.

**The MB100 two-way amplifier offers 1 GHz bandwidth capability, high gain, high output level, ergonomics, and superior distortion performance with the option to bench upgrade to N-split (5-85/104-1003 MHz) in the future.**

### BENEFITS INCLUDE:

- 1003 MHz Enhanced Gallium Arsenide (E-GaAs) power doubling technology
- High gain
- High output level
- Multiple diplex filter options
- Future N-split (5-85/104-1003 MHz) availability
- Ease-of-use ergonomics
- 16 dB return loss
- 60/90 V powering
- Meets Telcordia GR-1098-Core voltage surge requirements using surge waveforms as described in IEEE C62.41
- FCC, CENELEC and CCC approved
- RoHS compliant models available Q1 2007
- Bode equalization (thermal or auto controlled)
- 15 Ampere AC capability
- Optional return path ingress control and status monitor
- Power factor corrected power supply
- Directional coupler –20 dB test points



Motorola, Inc.  
101 Tournament Drive  
Horsham, PA 19044  
[www.motorola.com/broadband](http://www.motorola.com/broadband)



MOTOROLA, the Stylized M Logo, STARLINE, Mini-Bridger, and LIFELINE are registered in the US Patent & Trademark Office. All other product or service names are the property of their respective owners.  
© Motorola, Inc. 2006. All rights reserved.

04.03.07  
Rev 8

Specifications are subject to change without notice.

## BACKWARD COMPATIBILITY

The MB100 electronics package can be made backward compatible with the 10-Amp MB\*/\* housing by installing the MB-15A Kit or the MB-15A Kit II. These kits contain 50 mil gold plated platform assemblies. This makes it possible for the amplifier to carry 15 Amperes continuous through the input or output ports. There is also a "low current" (10A) model available that can be ordered as an electronics module (no housing included), which is backward compatible with the 10-Amp MB housing, without the use of a kit.

## FORWARD PATH

The operational gain of the MB100 is 42 dB, with 16 dB return loss. Output level control is achieved through the use of an interstage Bode equalizer, which compensates for coaxial cable attenuation changes due to temperature. Equalization may be controlled manually, with a thermal drive unit (TDU), or with a single pilot closed loop automatic drive unit, model ADU-\* (analog pilot) or QADU-\* (QAM pilot). Both the ADU and QADU boards are common to the STARLINE family of amplifiers (with the exception of the SLE). ADUs utilize Surface Acoustic Wave (SAW) filters for determining pilot frequency. This improves amplifier stability over temperature.

To further ensure system flexibility, installation ease and maintenance, the amplifier is engineered for compatibility with standard accessories, such as attenuators, equalizers, ADUs or QADUs, return amplifiers, automotive fuses and FTEC crowbar circuits.

For an optional third output, the MB100 utilizes splitters (model SP100) and directional couplers (model DC100/\*). The SP100, DC100/8, DC100/10, and DC100/12 offer superior performance to 1 GHz.

The MB100 uses modular diplex filters, which can be changed for a different frequency split as required. The amplifier is available with S-split filters for a 5-40 MHz return and a 52-1003 MHz forward band. K-splits (5-42 MHz/54-1003 MHz), J-splits (5-55 MHz/70-1003 MHz), and A-splits (5-65 MHz/85-1003 MHz) are also available. The N-split (5-85 MHz/104-1003 MHz) option is currently in development. These same filters can be used for all US-style Motorola RF distribution amplifiers (models BLE, MB/MBE, BT).

## RETURN PATH

High gain return amplifier kits can be ordered which provide 20 dB minimum station gain. Return path equalizers from 0 to 12 dB can be customer selected. Optional features include thermal compensation and ingress control switching. Thermal compensation comes in the form of a plug-in JXP-TH\*C, which stabilizes gain and match over temperature extremes.

Also available is Ingress Control Switching (ICS) in 3 states. This pin diode attenuator circuit can lower levels by 6 dB or by 38 dB with a controlled slew rate for minimum bit errors. The LIFELINE® Mini-Bridger amplifier transponder (available directly from AM Networks) is required to operate the Ingress Control Switch from a remote location.

## Model Availability

To reduce customer costs and to accommodate customer specific needs, the STARLINE MB100 can be ordered in a variety of different models. *Please refer to the MB100 ordering information below for options.*



## MB100 Specifications

*All specifications stated as worst-case over temperature unless otherwise noted.*

**STARLINE®**

**2 Port, Parallel E-GaAs Hybrid**

**Enhanced Gallium Arsenide  
1 GHz Mini-Bridger Amplifier**

**MB100S Specifications**

PARAMETER	UNITS NOTE		FORWARD	RETURN
				RA-KIT/H
Passband	MHz	1	52-1003	5-40
Flatness	dB	2	± 0.70	± 0.50
Minimum Full Gain	dB	3	46	NA
Operational Gain	dB	4	42	20
Manual Bode Slope Control Range	dB	5	± 4	NA
Interstage Equalizer Slope	dB	6	14 ±1	NA
Noise Figure 40/52/1003MHz	dB	7	NA / 8 / 8	8 / NA / NA
Reference Frequency	MHz	8	1003 / 550 / 52	
Output Level	dBmV		45 / 44 / 37	35 flat
Channel Loading	NTSC		79	6
Compressed data loading	MHz	20	450	NA
Distortion (max)	CTB	dBc 9,19,21	76.5	88
	XM	dB 10,19	68.5	77
	CSO	dBc 9,11,19	71	81
Test Point (all)	dB	12	20 ±1.0	
Return Loss	dB	13	16	
Hum Modulation @ 12A		dBc 14	70 (52 - 900 MHz)	60 (5 - 10 MHz)
			65 (901 - 1003 MHz)	70 (11 - 40 MHz)
Hum Modulation @ 15A		14	65 (52 - 900 MHz)	55 (5 - 10 MHz)
			60 (901 - 1003 MHz)	65 (11 - 40 MHz)
DC Voltage	VDC	15		
Current DC	mA	16	1475	1610
DC Ripple	mV		15 P-P	
Power Consumption	W		44.0	48
AC Input Voltage Range	VAC		38 - 90	
AC Current Draw		A 17	Forward Only	With Return
	@90 VAC		0.51	0.55
	@75 VAC		0.62	0.68
	@60 VAC		0.74	0.81
	@53 VAC		0.85	0.92
	@45 VAC		0.95	1.08
	@38 VAC		1.2	1.31
AC Bypass Current	All Ports	A 17	15 (or 10 amp option)	
Group Delay (max)	55.25 to 58.83 MHz	nSec 18	32	NA
	5.0 to 6.5 MHz	nSec	NA	45
	10.0 to 11.5 MHz	nSec	NA	10
	33.5 to 35.0 MHz	nSec	NA	12
	38.5 to 40.0 MHz	nSec	NA	32
Housing Dimensions			15.4"L x 5.5"W x 9.6"D	39.1cm x 13.97cm x 24.3 cm
Weight			15 lbs	6.8 kg
Ambient Operating Temperature			-40° to +140° F	-40° to +60° C



**Specification Notes:**

1. Operating passband of station. Diplex filters are plugged into the electronic chassis.
2. Referenced to the average gain across the stated passband.
3. Minimum full gain at 1003 MHz includes loss of equalizer but Bode slope reserves have not been set. Return gain includes loss of SRE-4 return equalizer.
4. Operational gain includes loss of slope reserves as well as equalizer.
5. Amount of Bode slope control range from midpoint (typical setting is -4 dB at 1003 MHz @ 20°C). This control should not be used for gain reduction.
6. Amount of slope created and cable equivalence of fixed interstage equalizer. Interstage equalizer is a plug-in.
7. Noise Figure is specified at the cable entry facility of the housing and includes the loss of 1 dB for the pre-stage equalizer. The return Noise Figure includes the station loss preceding the RF hybrid.
8. Frequencies that relate the picture carriers or passband edges to the specified output levels and tilts.
9. Measured with CW carriers and spectrum analyzer over specified temperature range. References the worst-case channel. Specifications are compliant with the test methods as stated in NCTA RECOMMENDED PRACTICES FOR MEASUREMENTS ON CABLE TELEVISION SYSTEMS.
10. Measured with wave analyzer and synchronous, 100% depth modulated channels. References the worst-case channels over specified temperature range. Specifications are compliant with the test methods as stated in NCTA RECOMMENDED PRACTICES FOR MEASUREMENTS ON CABLE TELEVISION SYSTEMS.
11. Composite Second Order distortion refers only to those beat clusters that fall +0.75 MHz and +1.25 MHz above the subject picture carrier. CSO beat clusters that have a -0.75 MHz and -1.25 MHz relationship to the subject picture carrier are not included in this specification.
12. Test points should be used with GFAL adaptor.
13. Match measurement at the station input and output, cable-entry facilities, at the specified passbands for operational gain.
14. Measured with the stated AC Bypass Current.
15. Measured at the power connector.
16. Current draw at +24.0 VDC.
17. AC current is stated in RMS continuous. A 10-amp compatible electronics package is also available for installing into older 10-amp housings during upgrades.
18. Group Delay is specified for standard NTSC video, where delay is the delta from picture carrier to 3.58 MHz color subcarrier. Reverse delay is in a 1.5 MHz bandwidth.
19. Distortion numbers are worst case over temperature in a cascade.
20. The compressed data loading is QAM carriers and are -6 dB relative to the analog CW carriers.
21. CTB (Composite Triple Beat). At the specified channel loading, Enhanced Gallium Arsenide performance varies on a two point three-for-one (2.3:1) basis with amplifier output level.

## MB100 Block Diagram

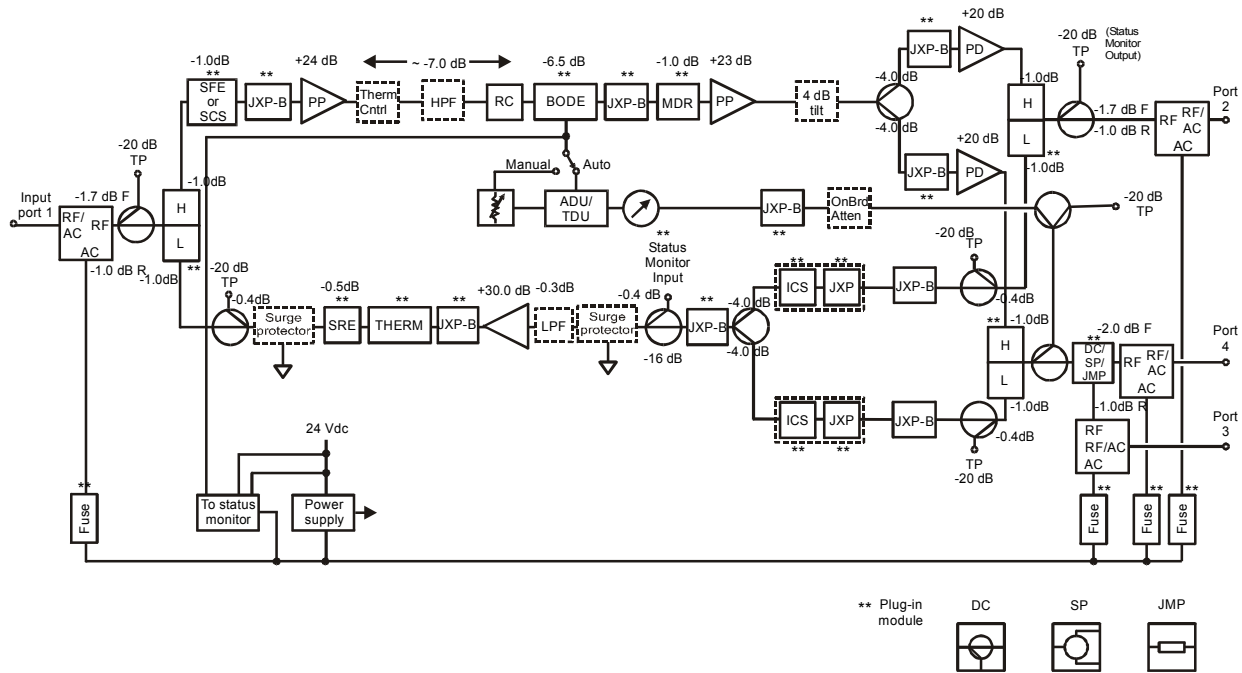

Motorola, Inc.  
 101 Tournament Drive  
 Horsham, PA 19044  
[www.motorola.com/broadband](http://www.motorola.com/broadband)



MOTOROLA, the Stylized M Logo, STARLINE, Mini-Bridger, and LIFELINE are registered in the US Patent & Trademark Office. All other product or service names are the property of their respective owners.  
 © Motorola, Inc. 2006. All rights reserved.

## MB100 Ordering Information

Model	Description	Motorola Part Number	Qty per MB
MB100S-2HQXH-F	5-40 / 52-1003 MHz S-split, two output, 42 dB high gain forward, QAM ADU 609.00 MHz gain control, 14 dB internal slope, high gain return, full station	721000-001-00	
MB100S-2HAXH-F	5-40 / 52-1003 MHz S-split, two output, 42 dB high gain forward, ADU 499.25 MHz gain control, 14 dB internal slope, high gain return, full station	721000-002-00	
MB100S-2HTXH-F	5-40 / 52-1003 MHz S-split, two output, 42 dB high gain forward, TDU gain control, 14 dB internal slope, high gain return, full station	721000-003-00	
MB100S-2HXXH-F	5-40 / 52-1003 MHz S-split, two output, 42 dB high gain forward, manual gain control, 14 dB internal slope, high gain return, full station	721000-004-00	
MB100S-1HXXH-F	5-40 / 52-1003 MHz S-split, one output, 42 dB high gain forward, manual gain control, 14 dB internal slope, high gain return, full station	721000-005-00	
MB100S-2HSXH-F	5-40 / 52-1003 MHz S-split, two output, 42 dB high gain forward, QAM ADU 711.00 MHz gain control, 14 dB internal slope, high gain return, full station	721000-021-00	
MB100S-2HXXH-E15	5-40 / 52-1003 MHz S-split, two output, 42 dB high gain forward, manual gain control, 14 dB internal slope, high gain return, 15A electronics module only (no housing)	721000-006-00	
MB2-100SH ("vanilla" model)	5-40 / 52-1003 MHz S-split, 2-output, 42 dB high gain forward, manual gain control, 14 dB internal slope, no return, standard surge arrestor (no FTEC), full station	535746-001-00	
MB100K-2HQXH-F	5-42 / 54-1003 MHz K-split, two output, 42 dB high gain forward, QAM ADU 609.00 MHz gain control, 14 dB internal slope, high gain return, full station	721000-010-00	
MB100K-2HAXH-F	5-42 / 54-1003 MHz K-split, two output, 42 dB high gain forward, ADU 499.25 MHz gain control, 14 dB internal slope, high gain return, full station	721000-011-00	
MB100K-2HTXH-F	5-42 / 54-1003 MHz K-split, two output, 42 dB high gain forward, TDU gain control, 14 dB internal slope, high gain return, full station	721000-012-00	
MB100K-2HXXH-F	5-42 / 54-1003 MHz K-split, two output, 42 dB high gain forward, manual gain control, 14 dB internal slope, high gain return, full station	721000-013-00	
MB100K-1HXXH-F	5-42 / 54-1003 MHz K-split, one output, 42 dB high gain forward, manual gain control, 14 dB internal slope, high gain return, full station	721000-014-00	
MB100K-2HSXH-F	5-42 / 54-1003 MHz K-split, two output, 42 dB high gain forward, QAM ADU 711.00 MHz gain control, 14 dB internal slope, high gain return, full station	721000-027-00	
MB100K-2HXXH-E15	5-42 / 54-1003 MHz K-split, two output, 42 dB high gain forward, manual gain control, 14 dB internal slope, high gain return, 15A electronics module only (no housing)	721000-015-00	
MB2-100KH ("vanilla" model)	5-42 / 54-1003 MHz K-split, 2-output, 42 dB high gain forward, manual gain control, 14 dB internal slope, no return, standard surge arrestor (no FTEC), full station	535746-002-00	
MB100A-2HXXH-F-R	5-65 / 85-1003 MHz A-split, 2-output, high gain, manual gain control, standard 14 dB slope, high gain return, full station, RoHS compliant – <b>AVAILABLE Q2 2007</b>	821000-001-00	
MB100J-2HXXH-F-R	5-55 / 70-1003 MHz A-split, 2-output, high gain, manual gain control, standard 14 dB slope, high gain return, full station, RoHS compliant – <b>AVAILABLE Q2 2007</b>	821000-003-00	
<b>Required Accessories</b>			
SFE-100-0	Starline Forward 1003 MHz equalizer (0 dB) -or-	527333-001-00	1
SFE-100-1 to -22	Starline Forward 1003 MHz equalizer (values 1 to 22 dB in 1 dB steps) -or-	527296-001 to -022	
SCS-1 to SCS-10	Starline Cable Simulator (values 1 to 10 dB in 1 dB steps)	477888-001 to -010	
SRE-*.*	Starline Return Equalizer, 5-40 MHz (S-split), 5-42 (K-split), 5-55 (J-split), 5-65 (A-split), values 0-12 dB in 1 dB steps for S-split (2 dB steps for all other frequency splits)	478176-XXX-00	1
JXP-*.B	Plug-in attenuator/pad (values 0 to 26 dB, in 1 dB steps)	474011-XXX-00	≤ 9 (dual output)
<b>Optional Accessories</b>			
SP100	Splitter (1 GHz) to activate third output -or-	529863-001-00	1
DC100/8	Directional Coupler (1 GHz) to activate third output (8 dB)	529864-001-00	
DC100/10	Directional Coupler (1 GHz) to activate third output (10 dB)	529864-002-00	
DC100/12	Directional Coupler (1 GHz) to activate third output (12 dB)	529864-003-00	



See next page for ordering guide/matrix.

### 1 GHz MB Ordering Guide

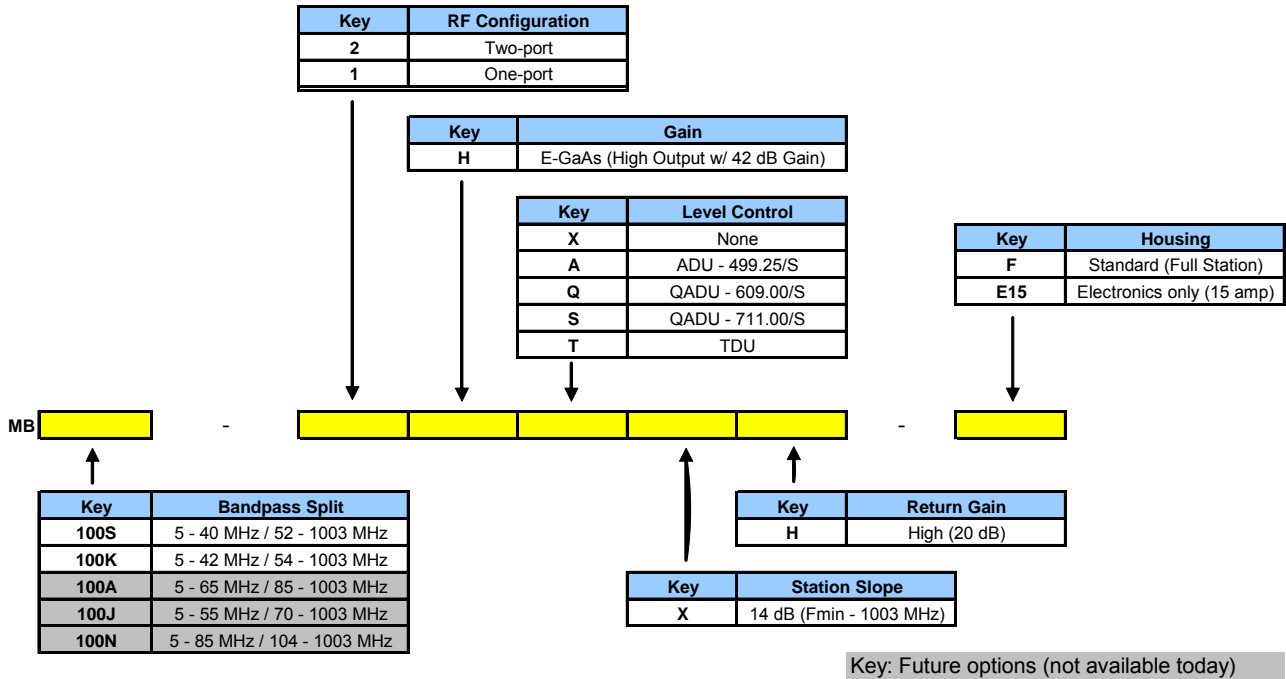

**Notes:**

- 1) Not all combinations in the ordering guide are available. This is a guide only. Please see "Ordering Information" (page 5) for available models.
- 2) FTECs are included in all models as standard, except for the "vanilla" models, MB2-100\*H, which contain the standard gas tube.
- 3) 20A fuses are included in all amplifiers as standard.
- 4) ICS and status monitor transponders will continue to be customer configurable options.
- 5) For RoHS models, add "-R" to end of model string.

